

50 CALIBER TWIST PEN

Required Accessories:

- 7mm pen mandrel
- 7mm Barrel trimmer
- 2-pc bushing set
- Insta-cure (cyanoacrylate) glue or 2-part epoxy glue

DIAGRAM A - Parts List

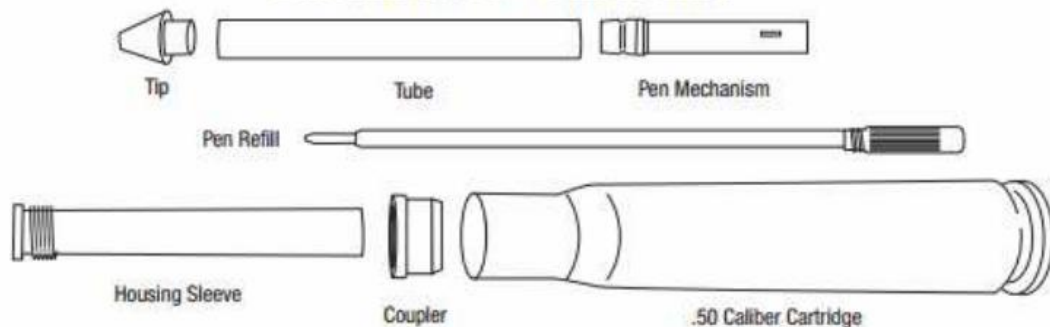

Preparing the Blank

- Cut 3/4" square blank to 1-3/16" (for 5-1/2" overall length pen) to 7/8" long (for a 6-3/16" overall length pen)
- Drill 7mm hole through the blank
- Spread glue over an end of the tube to the size of the blank. Slide on the wood. Leave some wood over the edge of the brass tube for trimming.
- (Note: The wood only covers a section of the tube).
- When the glue dries, use a 7mm barrel trimmer to trim the wood flush to the end of the brass tube.

DIAGRAM B - Squaring The Blank

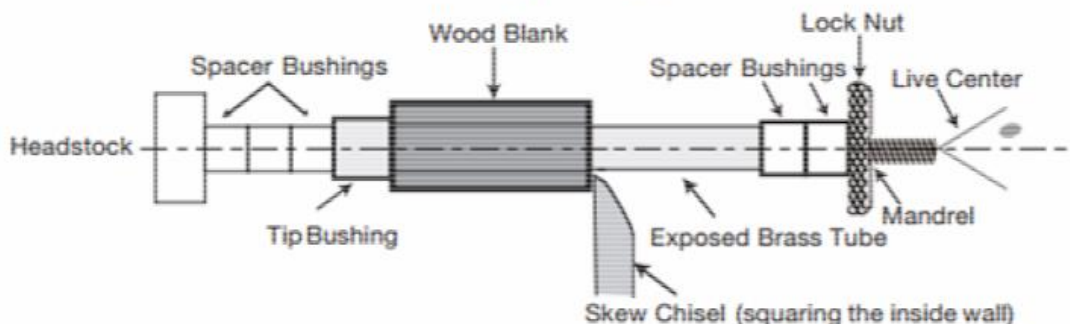

Turning the Blank

- Note: Before turning the blank the inside wall of the blank needs to be trimmed square on the lathe.
- Mount spacer bushings on the mandrel shaft. Insert the tip bushing.
- Insert the front-end assembly, wood side in first.

- Follow with 7mm spacer bushings, fill to the mandrel threads. Use locknut to lock in the setup then position the tailstock for turning.
- Use a skew chisel or a parting tool to square the inside wall of the wood blank (see Diagram B).
- When squared, remove nut and spacer from the mandrel.
- Insert the centre bushing over the brass tube; slide up tight to the wood. Add bushings as needed to close the space behind the outer bushing to the threads. See Diagram C. Lock in the set you then position the tailstock for turning. Turn the wood down close to the bushings. Follow the profile of an actual bullet on the wood barrel.
- Sand and polish the wood.

DIAGRAM C - Turning Profile To Bushings

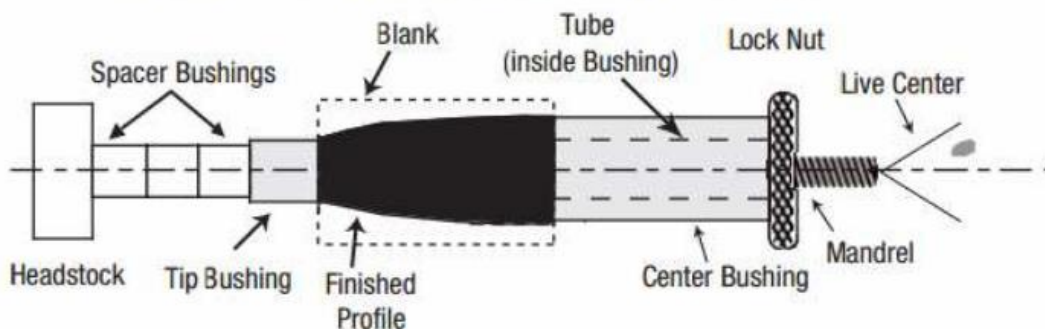
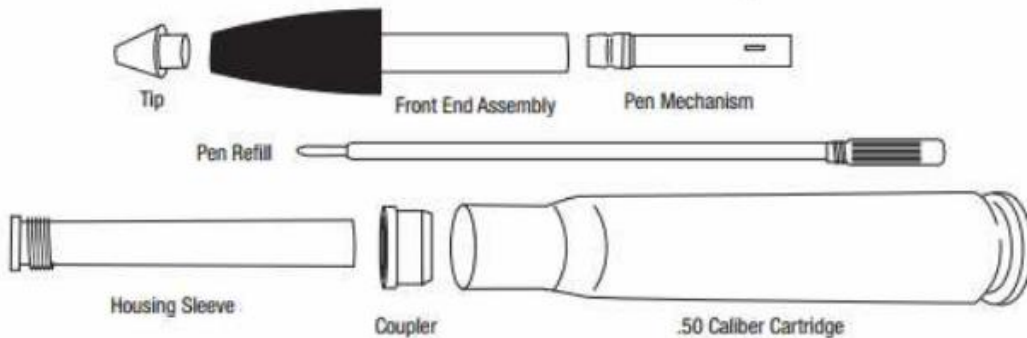

DIAGRAM D - Assembly



Assembly

- Press the tip into the wooden end of the assembly
- Press the pen mechanism, brass end in first into the opposite end to the indentation line. Insert the refill and test for refill tip extension.
- Press the coupler, narrow end in first into the opening of the cartridge until it seats.
- Thread the housing sleeve into the coupler
- Slide the exposed brass tube into the housing sleeve, push into bottom.
- The cartridge pen is ready to operate by twisting the ends.